

Micro Channel Cooled Horizontal Stack

High Power Laser Diode

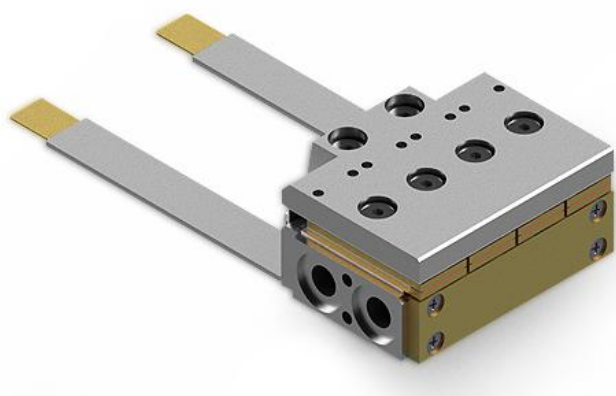

Features :

- ◆ Low Smile
- ◆ Long life time

Applications :

- ◆ Pumping
- ◆ Medical Use
- ◆ Scientific Research
- ◆ Material Processing

BWT, founded in 2003, is committed to the mission of "let the dream drive the light", the vision of becoming the "Global leader in laser solutions", and the value of "Outstanding innovation", providing diode laser, fiber laser, ultra-fast laser products and solutions to global customers.

The company pursues continuous innovation and insists on autonomous and controllable advanced process and technology. With Beijing headquarters as the core, BWT has successively established production and R&D centers in Jiangsu and Shenzhen, and invested in the construction of intelligent and digital production base in Tianjin. To bulid a high level of technical strength and product quality, BWT set up a German subsidiary in 2020, and taking a solid step for the internationalization of R&D, production and technological innovation.

Version number	Change content	Change date
00	First edition	2021.09.17

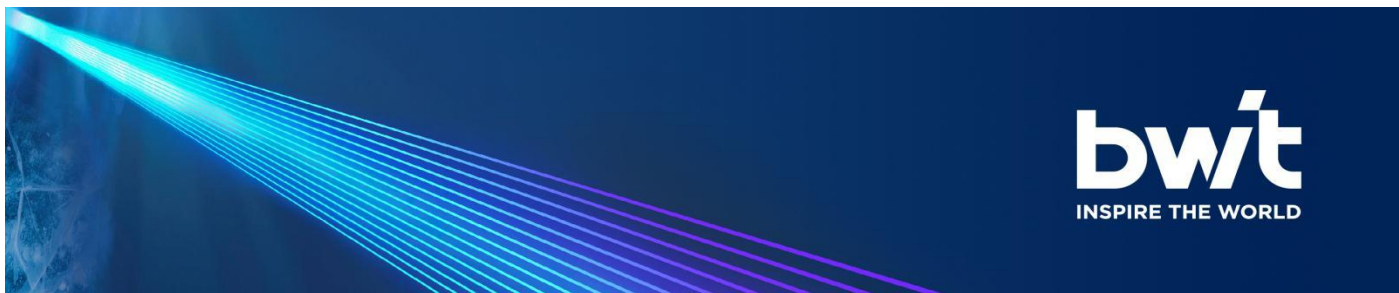

Micro Channel Cooled Horizontal Stack

High Power Laser Diode

Specifications (25°C)		Unit	E2Y-808.3-240C -1x4	E2Y-808.3-2000Q -1x4	E2Y-940.3-2000Q -1x4
Optical Data ⁽¹⁾	Working Mode	-	CW	QCW	QCW
	Central Wavelength	nm	808±3	808±3	940±3
	Output Power Per Bar	W/bar	60	500	500
	Bar Numbers	pcs	1~4	1~4	1~4
	Bandwidth(FWHM)	nm	< 5	< 5	< 5
	Fast Axis Divergence (95% power)	deg	60-70°	60-70°	60-70°
	Fast Axis Divergence with FAC (90% power)	mrad	≤8mrad	≤8mrad	≤8mrad
	Slow Axis Divergence (95% power)	deg	8-12°	8-12°	8-12°
Electrical Data	Threshold Current	A	≤20	≤40	≤40
	Operating Current	A	≤70	≤480	≤480
	Operating Voltage	V/bar	≤2	≤2	≤2
	Frequency	HZ	/	200-1000	200-1000
	Duty Cycle	%	/	≤10%	≤10%
	Slope	W/A	≥4.4	≥4.4	≥4.4
	Efficiency	%	≥50	≥50	≥50
Others	Cooling Water Temperature ⁽³⁾	°C	25	25	25
	Storage Temperature (2)	°C	0-55	0-55	0-55
	Pressure	Bar	<5	<5	<5
	Flow Rate	L/min/bar	<0.33	<0.33	<0.33
	Cooling Water Specification	-	Deionized water 2.5±0.5μS/cm,pH-value 5.5-8,filter≤5μm		

(1) Data measured under operation at nominal output power @25°C.

(2) A non-condensing environment is required for operation and storage.

(3) Operating temperature defined by the package case. Acceptable operating range is 20°C~30°C, but performance may vary.

(4) The data above are for reference only. For specific data, please refer to the delivery package data.

(5) Other wavelengths and configurations on customer request.



Micro Channel Cooled Horizontal Stack

High Power Laser Diode

Package Dimensions (mm)

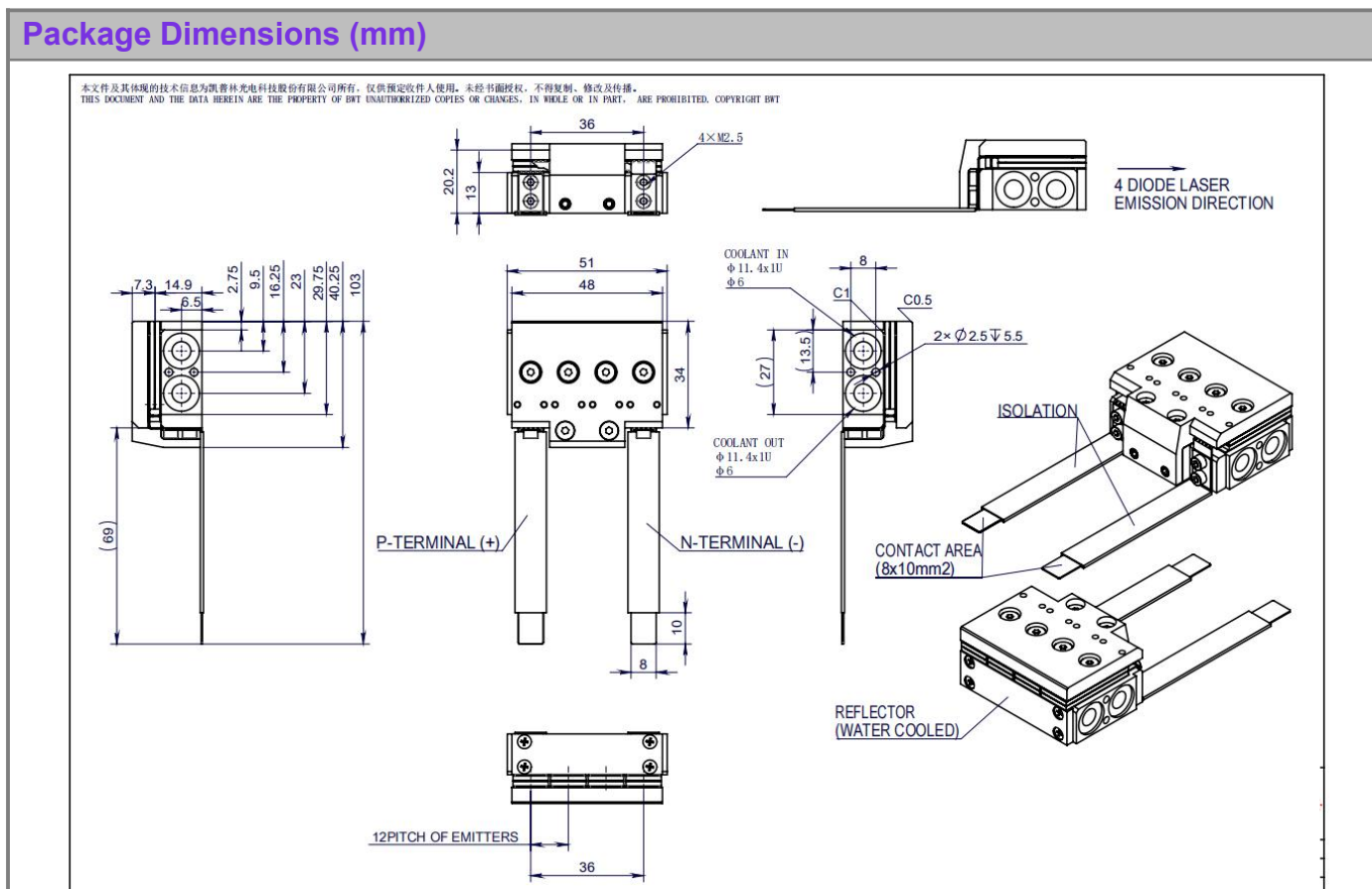

OPERATING NOTES

- ◆ Avoid eye and skin exposure to direct radiation during operation.
- ◆ ESD precautions must be taken during storage, transportation and operation.
- ◆ Short-circuit is required between pins during storage and transportation.
- ◆ Use constant current power supply to avoid surge current during operation.
- ◆ Laser diode must be used according to the specifications.
- ◆ Laser diode must work with good cooling.
- ◆ Operation temperature ranges from 20°C to 30°C .
- ◆ Storage temperature ranges from 0°C to +55°C.



Declaration: information and specifications contained herein are deemed to be reliable and accurate. BWT Beijing reserves the right to change, alter or modify the design and specifications of these products at any time without notice.21-1